

WATERPROOF STRAIGHT JACK CRIMP+HOUSING

R197.134.Z11

CABLE 2.6/50S

Series : **SMB**
CARLOCK

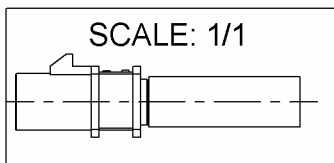
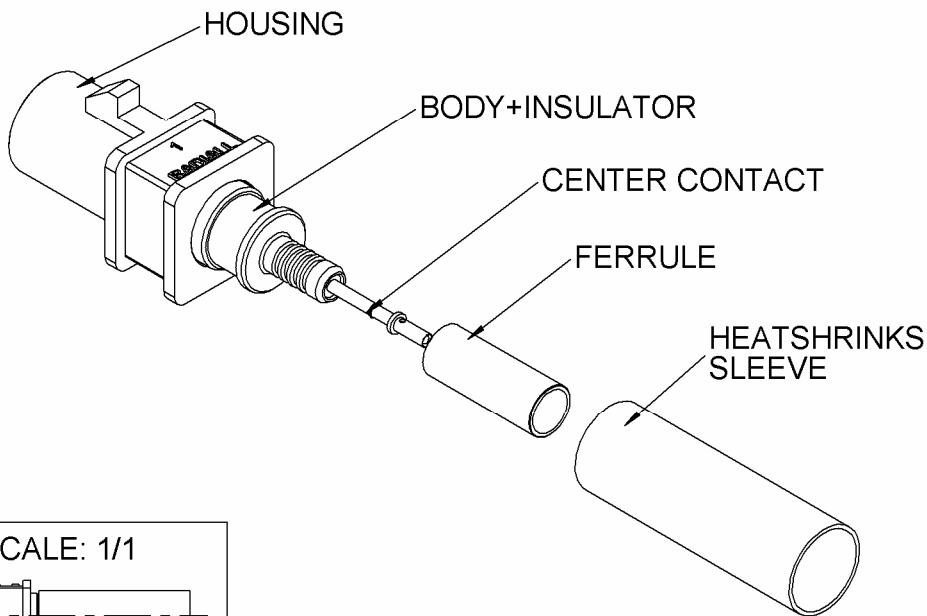
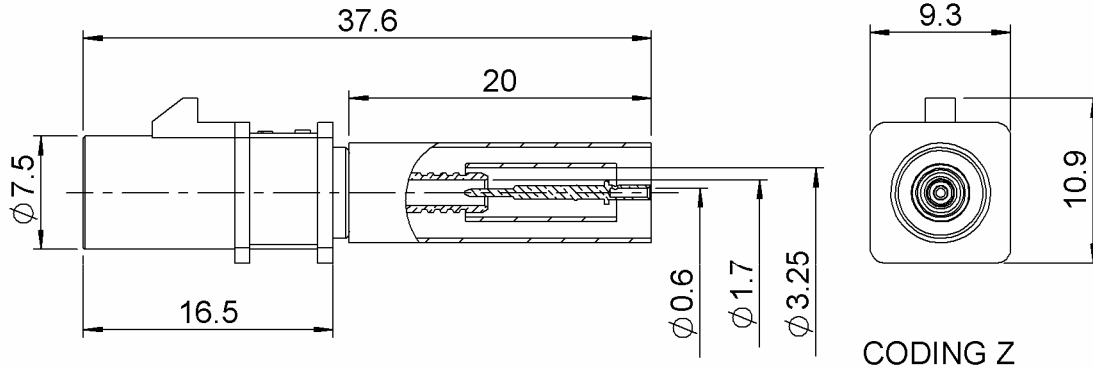

IP67 with connector R197.114.Z11 only

All dimensions are in mm.

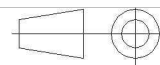

COMPONENTS	MATERIALS	PLATING (µm)
BODY	BRASS	NICKEL 2
CENTER CONTACT	BRASS	GOLD 0.8 OVER NICKEL 2
OUTER CONTACT		-
INSULATOR	PTFE	
GASKET	NBR 70	
OTHERS PARTS	BRASS	NICKEL 2
-	-	-
-	-	-
HOUSING	PA6.6 GF15 (POLYAMIDE)	UL CLASSIFICATION COLOR
		UL 94 V-2 SEE PAGE 3

Issue : 0747 A

In the effort to improve our products, we reserve the right to make changes judged to be necessary.



WATERPROOF STRAIGHT JACK CRIMP+HOUSING

R197.134.Z11

CABLE 2.6/50S

Series : **SMB**
CARLOCK

PACKAGING

Standard	Unit	Other
100	'W' option	Contact us

SPECIFICATION

QS9000 A 00

CABLE ASSEMBLY

Stripping	a	b	c	d	e	f
mm	2.40	5.50	14.7	0.00	12.3	0.00

ELECTRICAL CHARACTERISTICS

Impedance	50	Ω
Frequency	0-4	GHz
VSWR	1.20 + 0.0000	x F(GHz) Maxi
Insertion loss	TBD	\sqrt{F} (GHz) dB Maxi
RF leakage	- (TBD	- F(GHz)) dB Maxi
Voltage rating	335	Veff Maxi
Dielectric withstanding voltage	1000	Veff mini
Insulation resistance	1000	M Ω mini

Assembly instruction : **See page 4**

Recommended cable(s)
RG 174
RG 316

Characteristics indicated on this data sheet are those that can be achieved with the highest performance cable. Intrinsic limitations of the cable may diminish the performance of the assembly

Cable retention

- pull off
RG174 ***65** N mini
- RG316 **110** N mini
- torque **N.cm**

MECHANICAL CHARACTERISTICS

Center contact retention		
Axial force – Mating end	10	N mini
Axial force – Opposite end	10	N mini
Torque	NA	N.cm mini

Recommended torque		
Mating	NA	N.cm
Panel nut	NA	N.cm
Clamp nut	NA	N.cm
A/F clamp nut	0.0000	mm

Mating life	10	Cycles mini
Weight	3.1490	g

TOOLING

Part Number	Description	Hexagon
.	.	.
R282.235.915	CRIMPING DIES	Hex 3.25 square 0.72
R282.271.000	CRIMPING TOOL	Hex 3.25 square 0.72
R282.281.000	CRIMPING TOOL	2x4 pts 3 pos
R282.293.000	CRIMPING TOOL M22520/5-01	
R282.967.034	POSITIONER FOR TOOL R282 281	

ENVIRONMENTAL

Operating temperature	-40/+85	$^{\circ}$ C
Hermetic seal	NA	Atm.cm3/s
Panel leakage	IP67	

OTHER CHARACTERISTICS

*Depends on the cable used

Issue : **0747 A**

In the effort to improve our products, we reserve the right to make changes judged to be necessary.



WATERPROOF STRAIGHT JACK CRIMP+HOUSING

R197.134.Z11

CABLE 2.6/50S

Series : SMB
CARLOCK

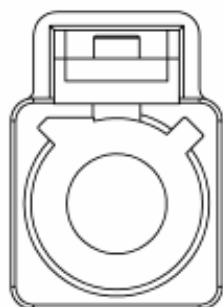

CODING A
COLOR BLACK
RAL 9005

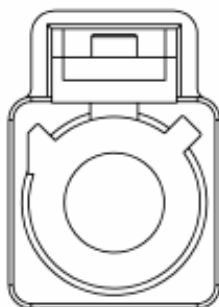

CODING B
COLOR CREAMWHITE
RAL 9001

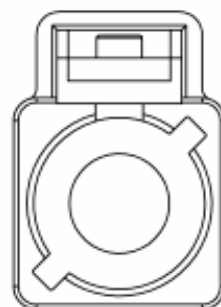

CODING C
COLOR BLUE
RAL 5005

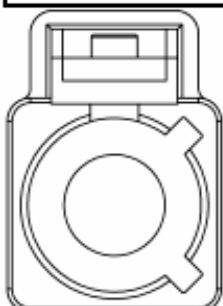

CODING D
COLOR BORDEAUX
VIOLET
RAL 4004

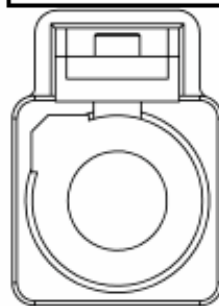

CODING E
COLOR GREEN
RAL 6002

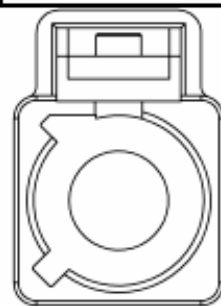

CODING F
COLOR BROWN
RAL 8011

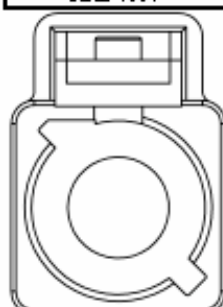

CODING G
COLOR GREY
RAL 7031

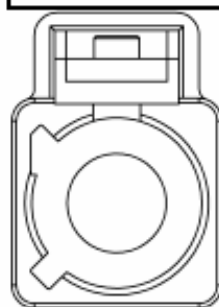

CODING H
COLOR VIOLET
RAL 4003

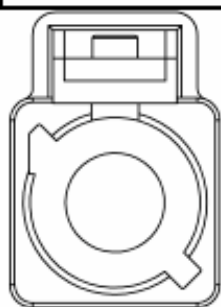

CODING I
COLOR BEIGE
RAL 1001

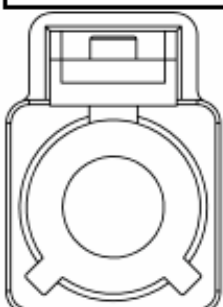

CODING K
COLOR CURRY
RAL 1027

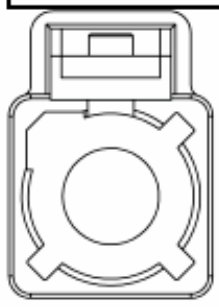

CODING Z
COLOR WATER BLUE
RAL 5021

UL CLASSIFICATION
UL 94V-2

**According to FAKRA specifications*

-To obtain the complete P/N please fill in the blank " _ " with the coding letter

Issue : 0747 A

In the effort to improve our products, we reserve the right to make changes judged to be necessary.



WATERPROOF STRAIGHT JACK CRIMP+HOUSING

R197.134.Z11

Series : SMB
CARLOCK

CABLE 2.6/50S

COMPONENTS

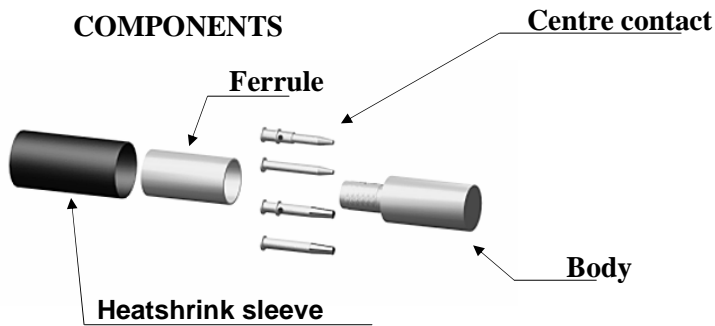

STRIPPING DIMENSIONS

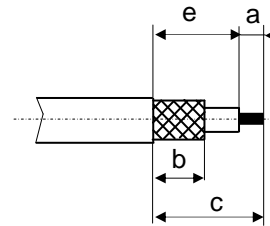

1

Slide the heat shrink sleeve onto the cable.
Slide the ferrule onto the cable.
Strip the cable.

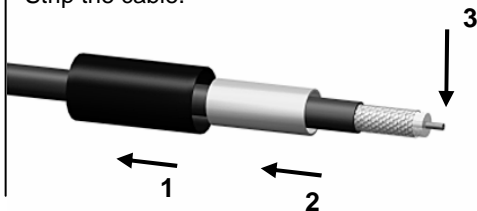

4

Slide the cable into the body until it bottoms against the insulator.

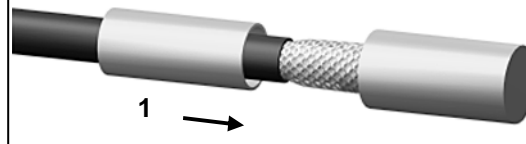

2

Slide the centre contact on until it bottoms against the cable dielectric.
Crimping the centre contact with square 0.75



5

Slide the ferrule over the braid.
Crimp the ferrule with crimping tool (see connector TDS).

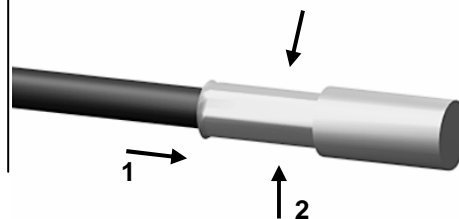

3

Fan the braid.

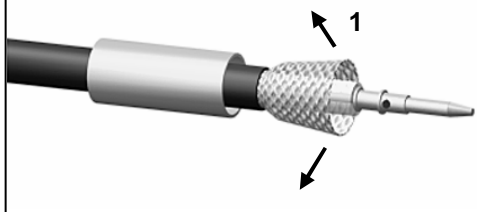

6

Cut the excess of braid if necessary.
Slide the sleeve over the ferrule and heat shrink it in place.



Issue : 0747 A

In the effort to improve our products, we reserve the right to make changes judged to be necessary.



RADIALL®